

Adaptors



ZF43 Spark Plug Adaptor of size M14

The combination of a M14 spark plug adaptor with a pressure sensor still represents a well accepted solution for indicating of gasoline engines.

For this reason AVL offers the spark plug adaptor ZF43 as the successor of the ZF42 with several optimizations.

With introduction of the ZF43 a new insulator with a massive platinum electrode of the supplier BOSCH is applied. Furthermore the ZF43 is equipped with a platinum reinforced mass electrode.

Because the outer shape of the ZF43 corresponds to the design of the original spark plug based on the ISO standard 8470 the use of the spark plug adaptor in combination with single coils and ignition rails is possible.

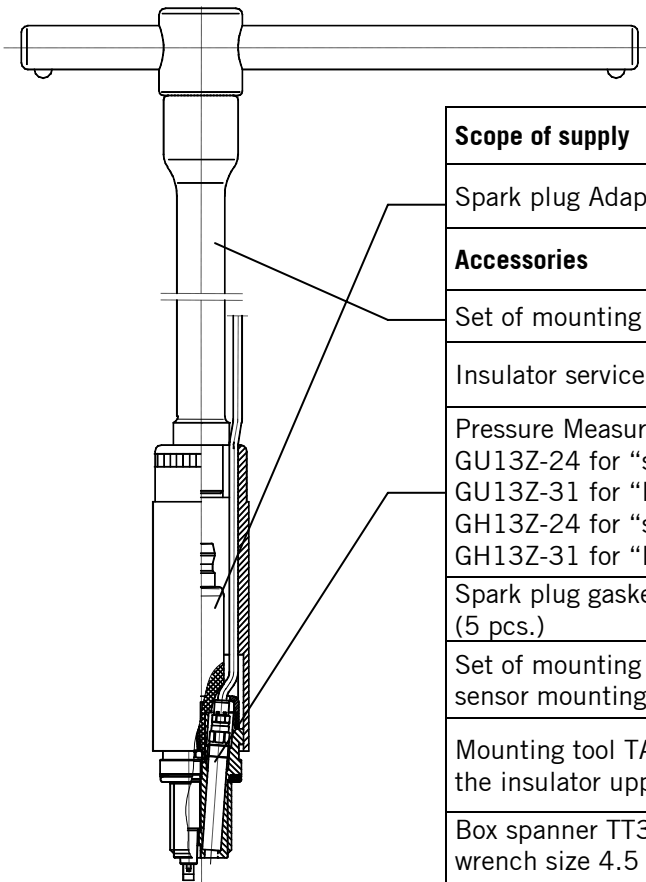

Scope of supply	Art. No.
Spark plug Adaptor ZF43	see table on page 2
Accessories	
Set of mounting tools	TIWG0211A.01
Insulator service kit	see table on page 2
Pressure Measuring Probe GU13Z-24 for "short" GU13Z-31 for "long" GH13Z-24 for "short" GH13Z-31 for "long"	TIGG827A.01 TIGG828A.01 TIGG929A.01 TIGG930A.01
Spark plug gasket SG43 (5 pcs.)	YF0722SP
Set of mounting tools for sensor mounting TS21	TIWG0213A.01
Mounting tool TA42 for the insulator upper part	TIWG0212A.01
Box spanner TT31 of wrench size 4.5 mm for insulator	TIWG0232A.01

Adaptors

ZF43 F5D PRT

Type of configuration
R ... Burn off resistance

General type

Mounting thread & type of seat

F ... M14x1.25 flat
H ... M14x1.25 conical

Number of ground electrodes
... 1

Electrode material
P ... Platinum

Electrode gap
T ... 0.8 mm

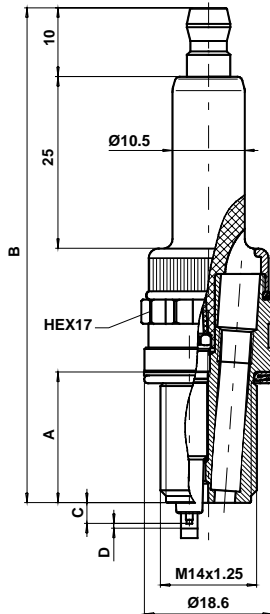

Heat range (Bosch)

3 ... cold
5
7 ... warm

Thread length and spark position

C ... 19.0 (flat) / 17.5 (con); C = 1 mm
D ... 19.0 (flat) / 17.5 (con); C = 3 mm
M ... 26.5 (flat) / 25.0 (con); C = 3 mm
L ... 19.0 (flat) / 17.5 (con); C = 5 mm
S ... 19.0 (flat) / 17.5 (con); C = 5 mm

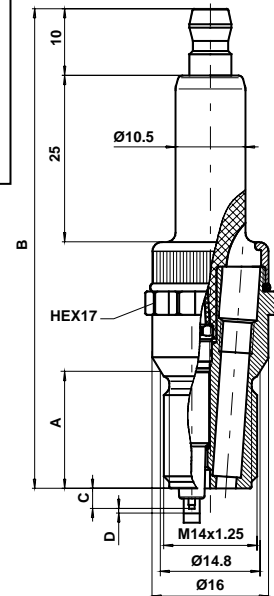

Art. No.	Identification	Sealing	Thread length A	Heat range	Total length B	Spark position C	Electrode gap D	Spare Isolator
			[mm]	[Bosch]	[mm]	[mm]	[mm]	
TIGG1071A.01	ZF43 F07CPRT	Flat	19	07	70,5	1	0.8	TIBW3591A.01
TIGG0966A.01	ZF43 F3CPRT	flat	19	3	70,5	1	0.8	TIBO7350A.01
TIGG0967A.01	ZF43 F5DPRT	flat	19	5	70,5	3	0.8	TIBO7351A.01
TIGG0968A.01	ZF43 F7DPRT	flat	19	7	70,5	3	0.8	TIBO7352A.01
TIGG0969A.01	ZF43 F7LPRT	flat	19	7	70,5	5	0.8	TIBO7353A.01
TIGG0970A.01	ZF43 F5MPRT	flat	26.5	5	78	3	0.8	TIBO7351A.01
TIGG0971A.01	ZF43 F7MPRT	flat	26.5	7	78	3	0.8	TIBO7352A.01
TIGG0972A.01	ZF43 F7SPRT	flat	26.5	7	78	5	0.8	TIBO7353A.01
TIGG1180A.01	ZF43 H07CPRT	conical	17.5	07	70,5	1	0.8	TIBW3591A.01
TIGG1147A.01	ZF43 H3CPRT	Conical	17.5	3	70,5	1	0.8	TIBO7350A.01
TIGG0973A.01	ZF43 H7DPRT	conical	17.5	7	70,5	3	0.8	TIBO7352A.01
TIGG0974A.01	ZF43 H7LPRT	conical	17.5	7	70,5	5	0.8	TIBO7353A.01
TIGG0975A.01	ZF43 H5MPRT	conical	25	5	78	3	0.8	TIBO7351A.01

Adaptors

TIGG0976A.01	ZF43 H7MPRT	conical	25	7	78	3	0.8	TIBO7352A.01
TIGG0977A.01	ZF43 H7SPRT	conical	25	7	78	5	0.8	TIBO7353A.01