

INJECTION TESTING

AVL PLU131F

FUEL FLOW MEASUREMENT

Function Summary

The AVL product line PLU131 offers a wide range of high precision flow meters for all kinds of applications in various fields of combustion engine development and production. It stands for high-precision flow rate measurement over large measuring ranges under rough environmental conditions. Furthermore PLU flow meters are known for high accuracy at low flow rates and for extremely long-term stable sensor calibration.

The PLU131F has been designed specifically for demanding test and calibration applications of Gasoline and Diesel injectors, pumps and valves in production lines and component test benches. Furthermore it is used for fuel consumption measurement of components like HC-dosers on engine test beds.

Functional Description

The AVL PLU131F Flow Meter is available for different measuring ranges range from small quantity measurement at 0,05 l/h up to high flow rates of 300 l/h. The measuring accuracy is 0.1% of the measured value over the complete measuring range (typically 1:400) of the individual device type.

AVL PLU131F Flow Meters are compatible with all kinds of fuels and test fluids and covering a pressure range of up to 10bar and standard media temperature range between -20 °C to +70 °C.

The dual PLU measuring principle is the combination of a rotational and a translational displacement meter. The servo-controlled gear counter determines the flow volume from the rotation. The dynamic piston sensor controls the engine speed and ensures zero pressure difference between ($\Delta p = 0$) between inlet and outlet. Thus, internal leakage flow in the sensor is prevented. Over the complete measuring range no pressure difference is generated in the hydraulically system to be measured by the measuring device.

Application

The AVL PLU131F Flow Meter is used in fuel injector and injection system development as well as in component production testing. Main fields of application are test benches and production lines for component testing e.g. quality assurance.

The PLU measuring principle is especially suitable for those applications with commonly occurring pulsating flows. Thus, it can be applied in direct hydraulic adaptation for the testing of pumps, injectors and control valves, which is increasing measurement accuracy and reducing measuring time. Moreover it provides for high-dynamic flow rate measurement, which is becoming increasingly important for combustion development and emission control.

AVL PLU131 sensors are suitable for continuous flow measurement in both configurations, in the inlet (upstream) as well as in the outlet (downstream) behind the component to be measured.

Flow sensor application in UPSTREAM configuration on the high-pressure side of the tested component offers a unique capability for dynamic flow measurement e.g. on an operating combustion engine.

In production testing upstream measurement reduces air purge and stabilization time and prevents problems due to contaminations remaining from component production.

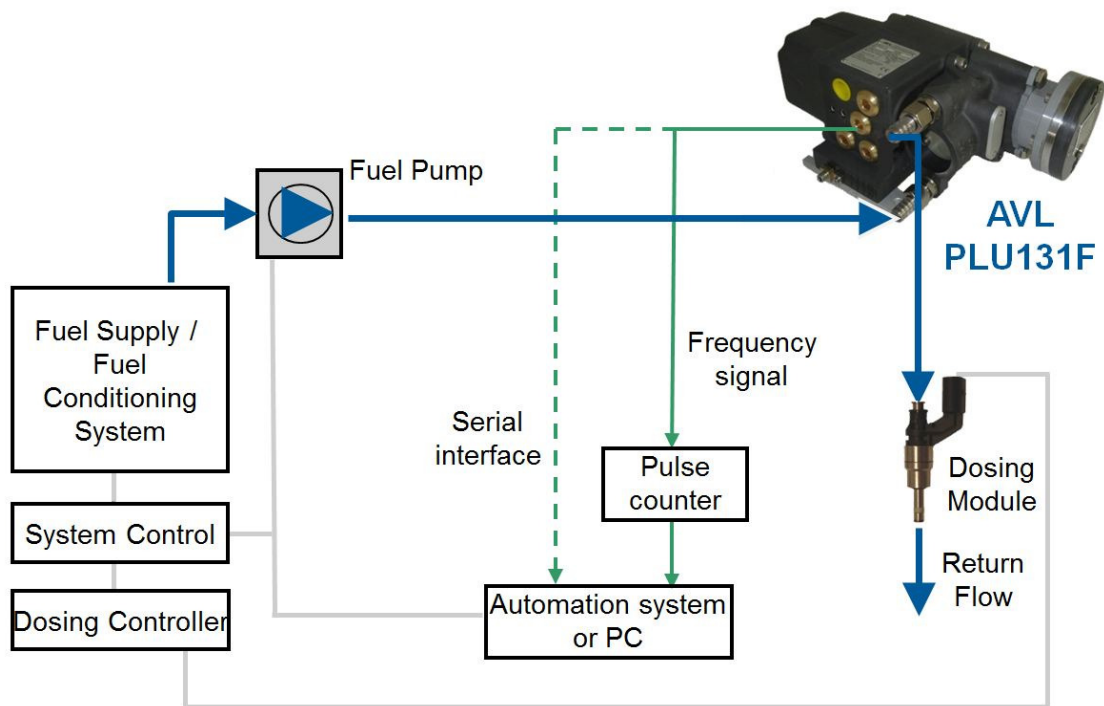

Funktional schematic injector test bench in UPSTREAM configuration

Benefits

- Reduced measurement time due to high precision flow rate measurement
- High flexibility due to broad range media compatibility and extremely large measuring ranges
- Reliable results with upstream measurement (high-pressure side) and non-interference between meter and hydraulic system ($\Delta p=0$)
- Low cost of ownership due to outstanding robustness and long-term stability of calibration



Component Description

Available AVL PLU131F Flow Meters:

Description	Specification	Part number
AVL PLU131F-010 Flow Meter	0.05...10l/h	TN131F010.01
AVL PLU131F-020 Flow Meter	0.05...20l/h	TN131F020.01
AVL PLU131F-040 Flow Meter	0.1...40l/h	TN131F040.01
AVL PLU131F-080 Flow Meter	0.15...75l/h	TN131F075.01
AVL PLU131F-150 Flow Meter	0.3...150l/h	TN131F150.01
AVL PLU131F-300 Flow Meter	0.8...300l/h	TN131F300.01

Technical Insight

Measurement parameters	Momentary flow rate Total consumption, gravimetric data, statistical data, temperature in combination with appropriate data acquisition system	
Flow measurement range	Type -010: 0.05...10l/h	Specified calibration ranges
	Type -020: 0.05...20l/h	
	Type -040: 0.1...40l/h	
	Type -080: 0.15...75l/h	
	Type -150: 0.3...150l/h	
	Type -300: 0.8...300l/h	
Measurement resolution	Type -010: 0.042mm ³	23.800 Pulse/cm ³
	Type -020: 0.078mm ³	12.900 Pulse/cm ³
	Type -040: 0.16mm ³	6.300 Pulse/cm ³
	Type -075: 0.29mm ³	3.400 Pulse/cm ³
	Type -150: 0.59mm ³	1.700 Pulse/cm ³
	Type -300: 1.2mm ³	840 Pulse/cm ³
Measurement uncertainty *)	0.1%	For sensor calibration factors of average flow rates
Dynamic response time	< 100 ms	Acc. to ISO 16183 (T10 ... T90)
Operating temperature:	Media: -20...+70 °C	
	Environment: -20...+60 °C	
Operating pressure:	0.1...10 bar	
Media:	Commercially available Gasoline and Diesel fuels and compatible test fluids; alcoholic additives up to 100%	
Media density:	0.69...0.85 g/cm ³	Further density ranges on request
Interface:	Frequency output (max. 80kHz)	Differential pulse signals according to RS485 standard
Hydraulic connection:	Inlet / Outlet connector: Fitting for 10mm outside diameter tube or hose	Alternatively 3/8" inside thread (max. 12mm length) after removal of tube fitting



Supply voltage:	24 V DC +20%/-10%	
Power consumption:	Max. 40 Watt	
Dimensions:	340mm x 216mm x 133mm (W x D x H)	Permitted mounting angle variation: max. 3°
Weight:	10 kg	
Safety:	Ex II 2 G EEx d IIB T6	
Safety:	CE	
Calibration:	Traceable to National Institute of Metrology (PTB)	

*) Measurement uncertainty of flow meter calibration factors within nominal measuring range under repeatable conditions with medium HAKU at 20°C and 1 bar pressure.

Scope of Supply

consisting of:

- 1 AVL PLU 131F Flow Meter
- 1 AVL PLU 131F Operating Manual
- 1 Calibration report

Compatibility

The AVL PLU 131F Fuel Flow Meter replaces the predecessor model AVL PLU131 with an expansion of media compatibility.

Options/Extensions

Adapter set for 3/8" NPT hydraulic fittings:

AVL PLU131S Adapter 3/8" NPT	TN131FAD38.01
------------------------------	---------------

Density Meter:

AVL SORE Density Meter external	TNSORDENEX.01
---------------------------------	---------------

Data acquisition system:

ACTUATOR-/ SENSOR- MODULE AVL PLU 4000 M	TNPLU4000.02
--	--------------

Extended measuring ranges, temperature ranges and pressure ranges etc. upon request.