

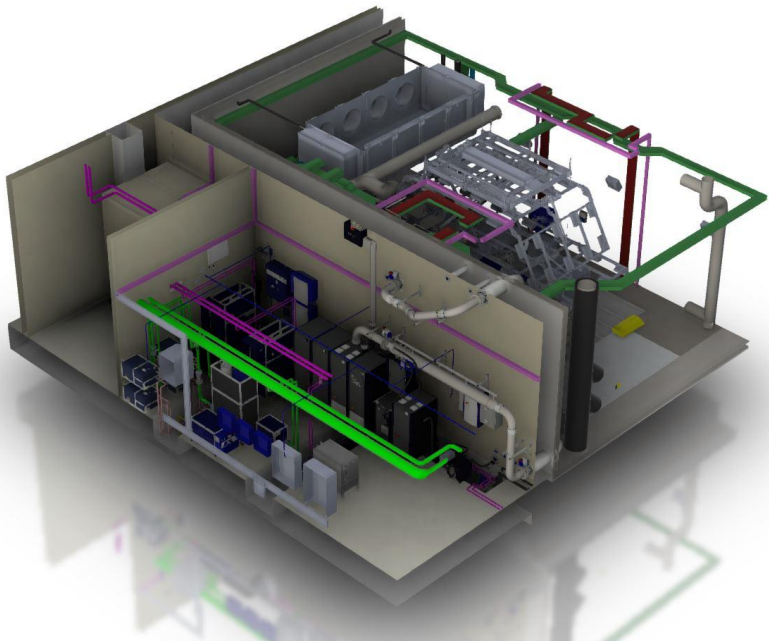

Energy Flow Testbed

Testbed Overview, Installation Setup, Vehicle Instrumentation, Data Acquisition System

Climatic Energy Flow Testbed Overview

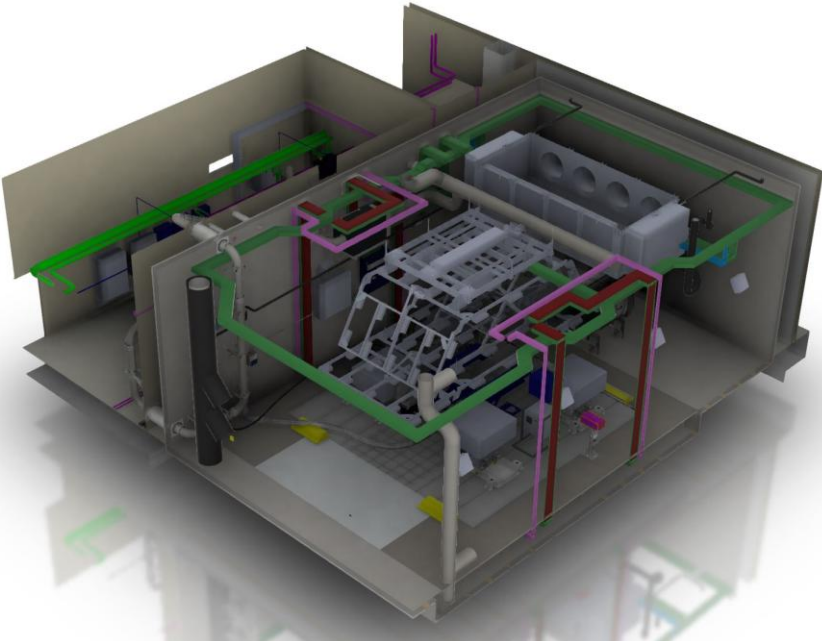
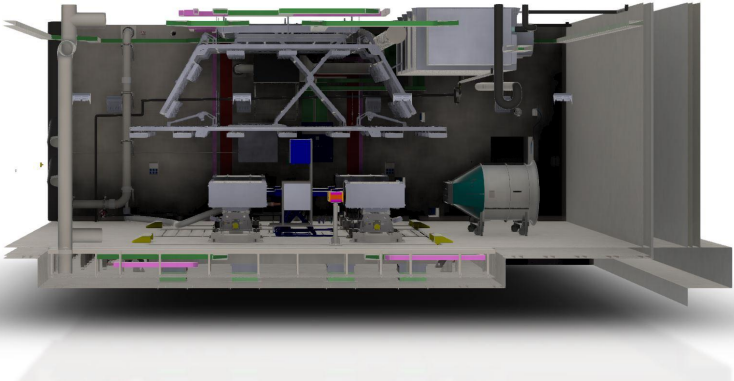
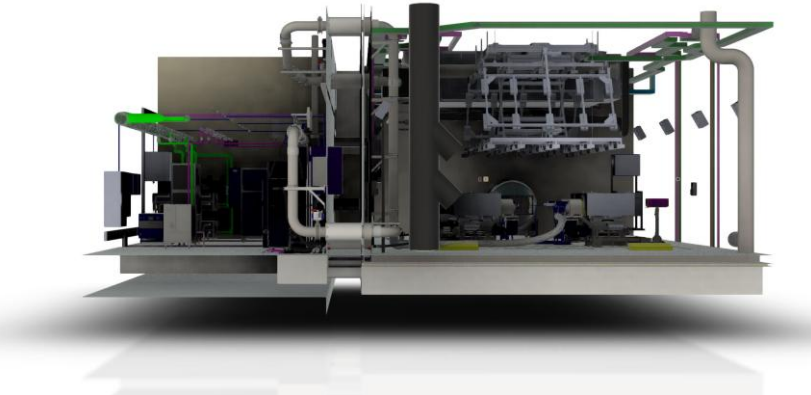

Climatic Energy Flow Testbed Overview

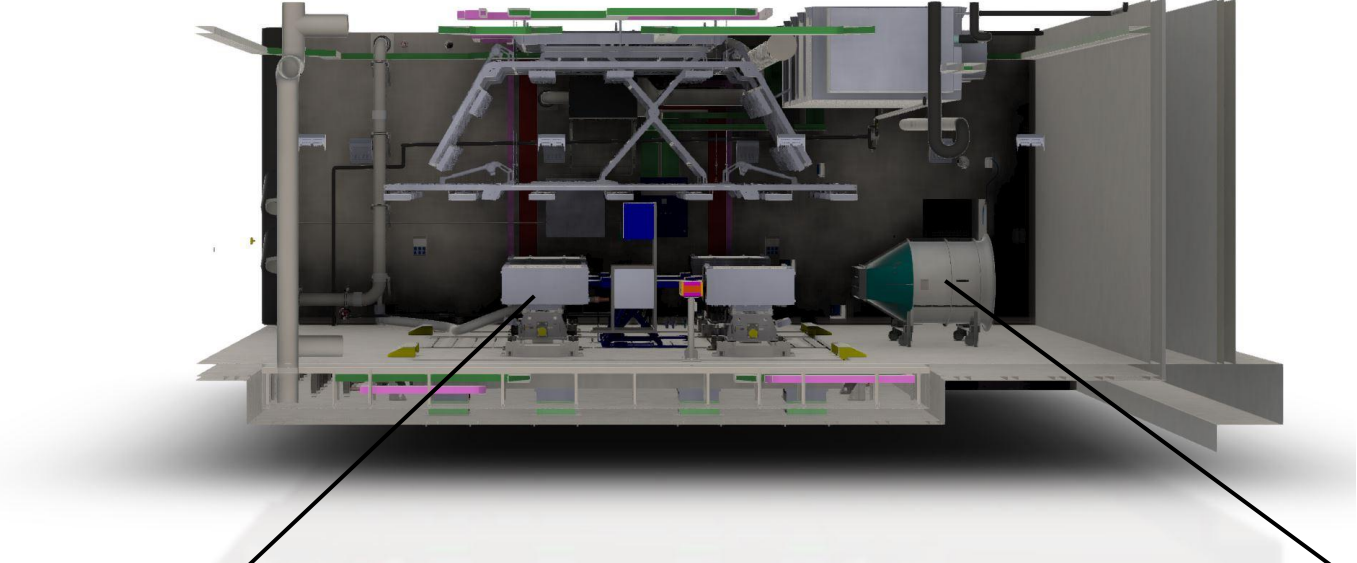

Wheel dynos

Wind simulation

Climatic Energy Flow Testbed Overview

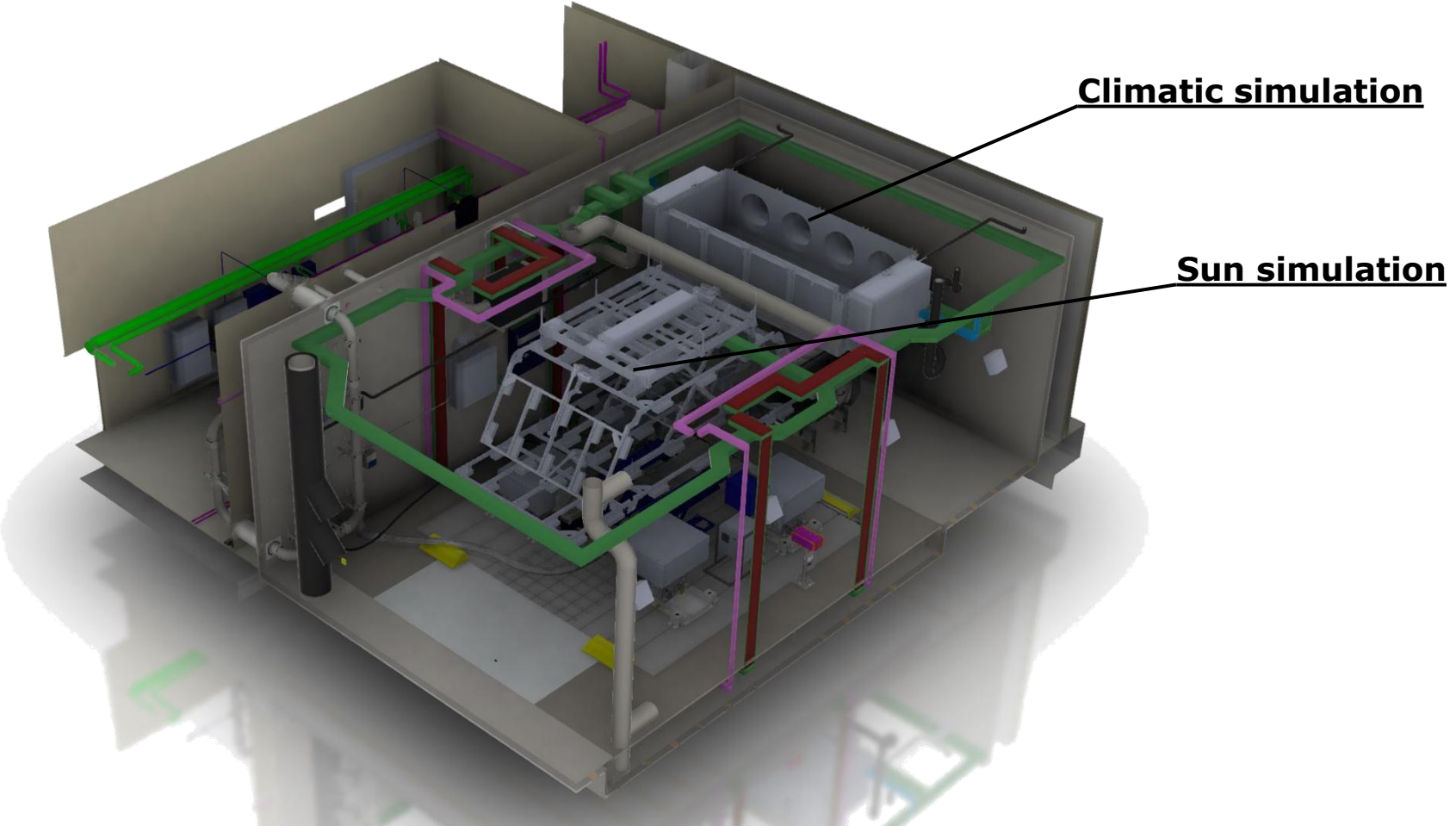

Climatic Energy Flow Testbed Overview

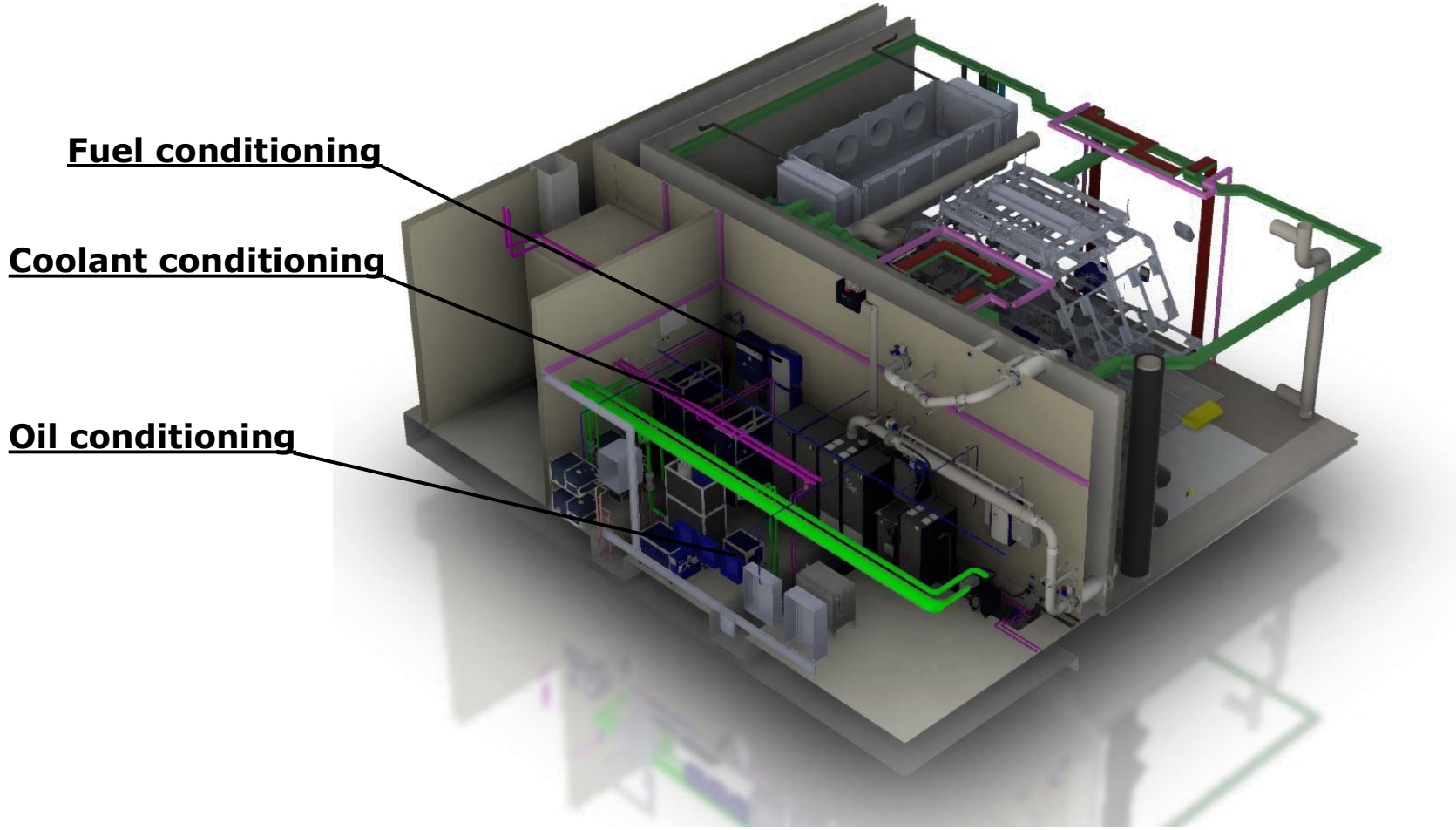



Installation Setup

Installation Setup: Exemplary Installations



Exemplary Installation Setup Vehicle-in-the-Loop (ViL)

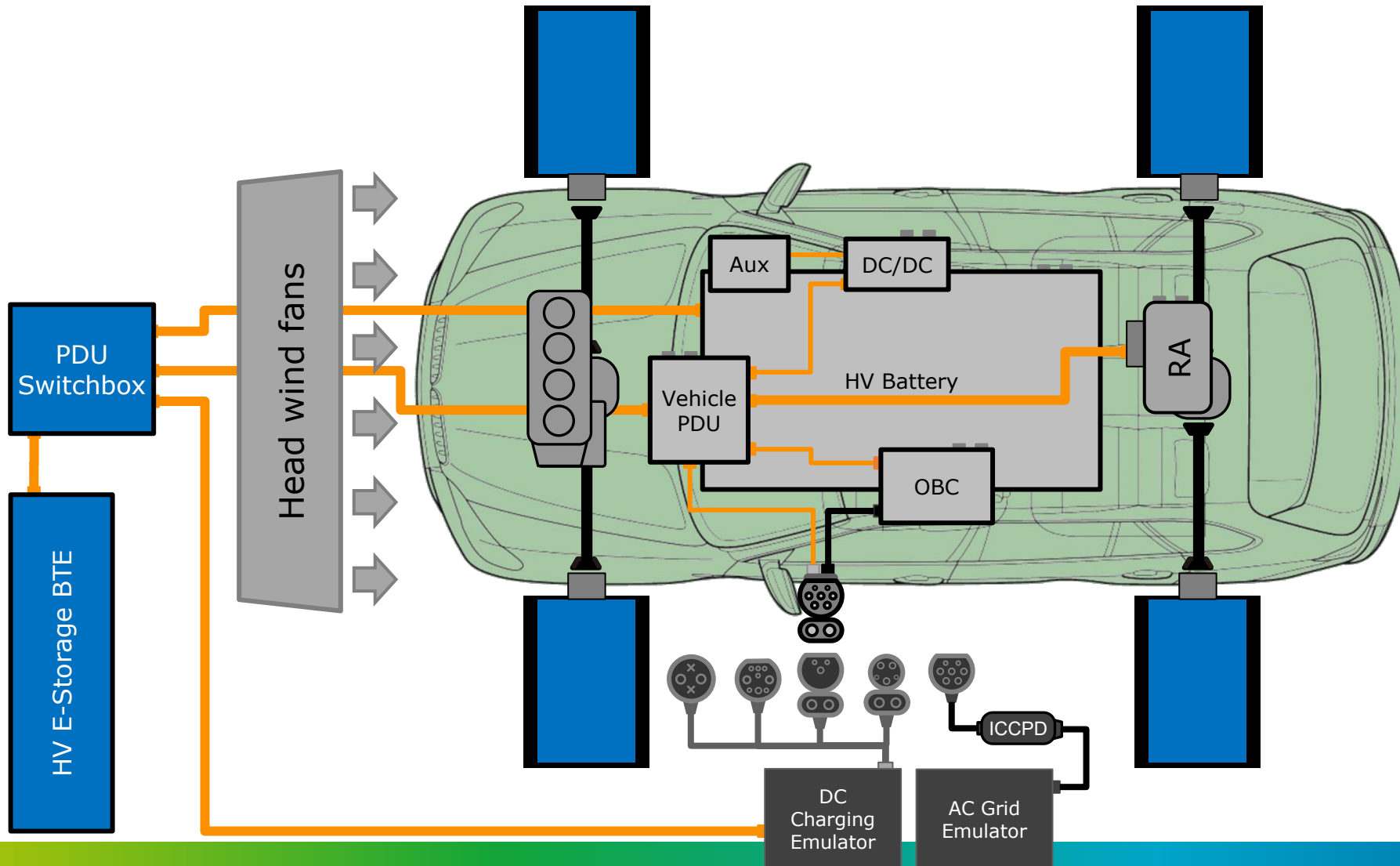

Exemplary Installation Setup Powertrain-in-the-Loop (PiL)

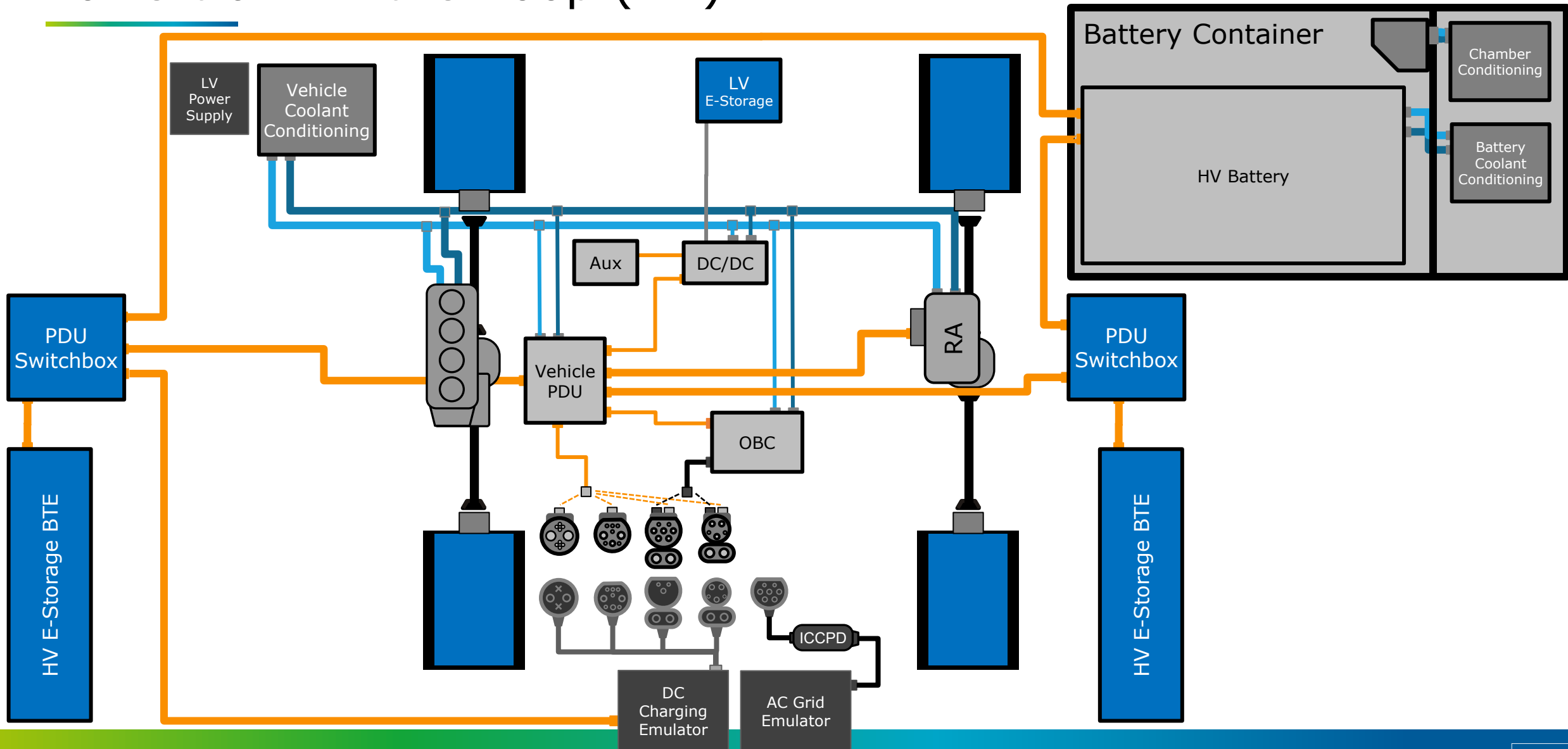



Vehicle Instrumentation

Exemplary Measurement Layout: Chemical, Electrical and Mechanical Energy Flow

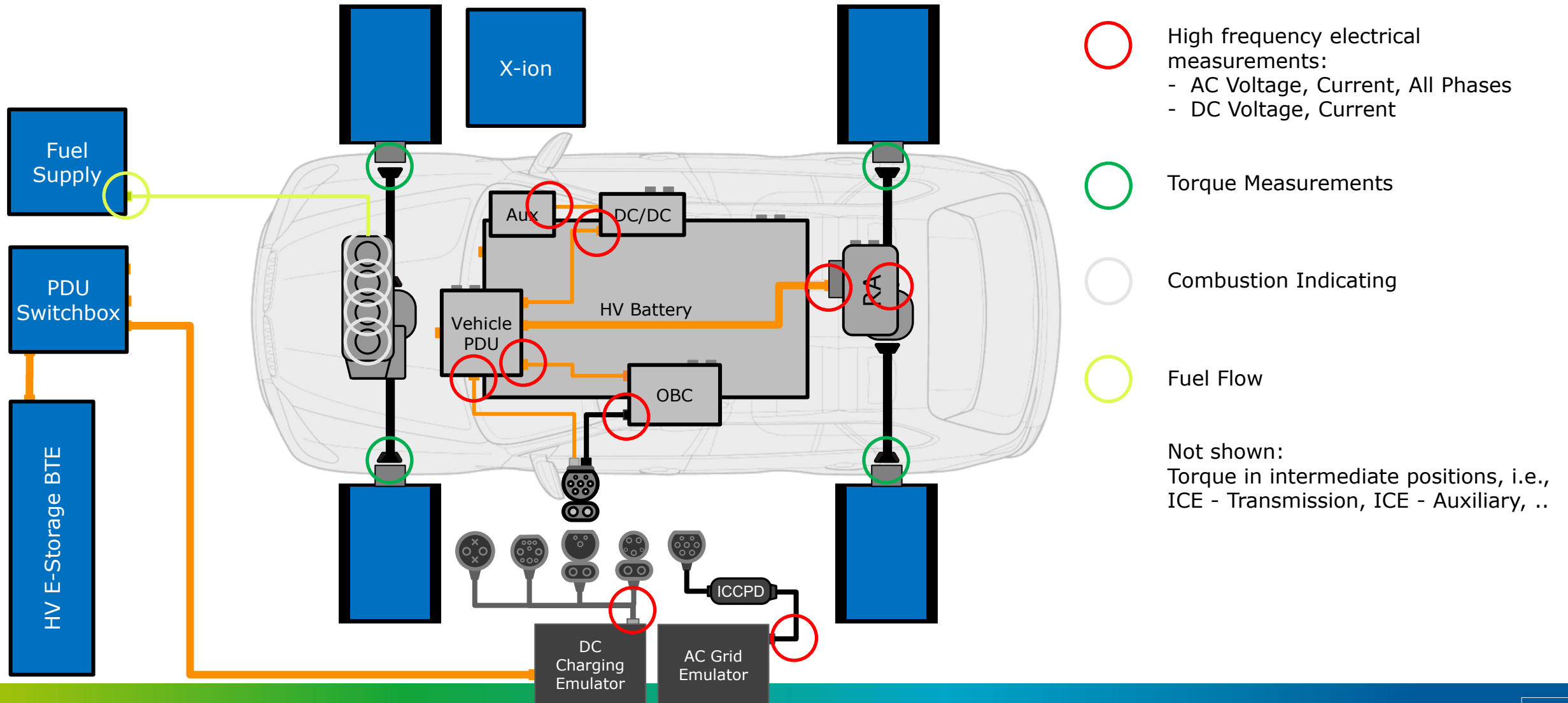

Exemplary Measurement Layout: Thermal Energy Flow

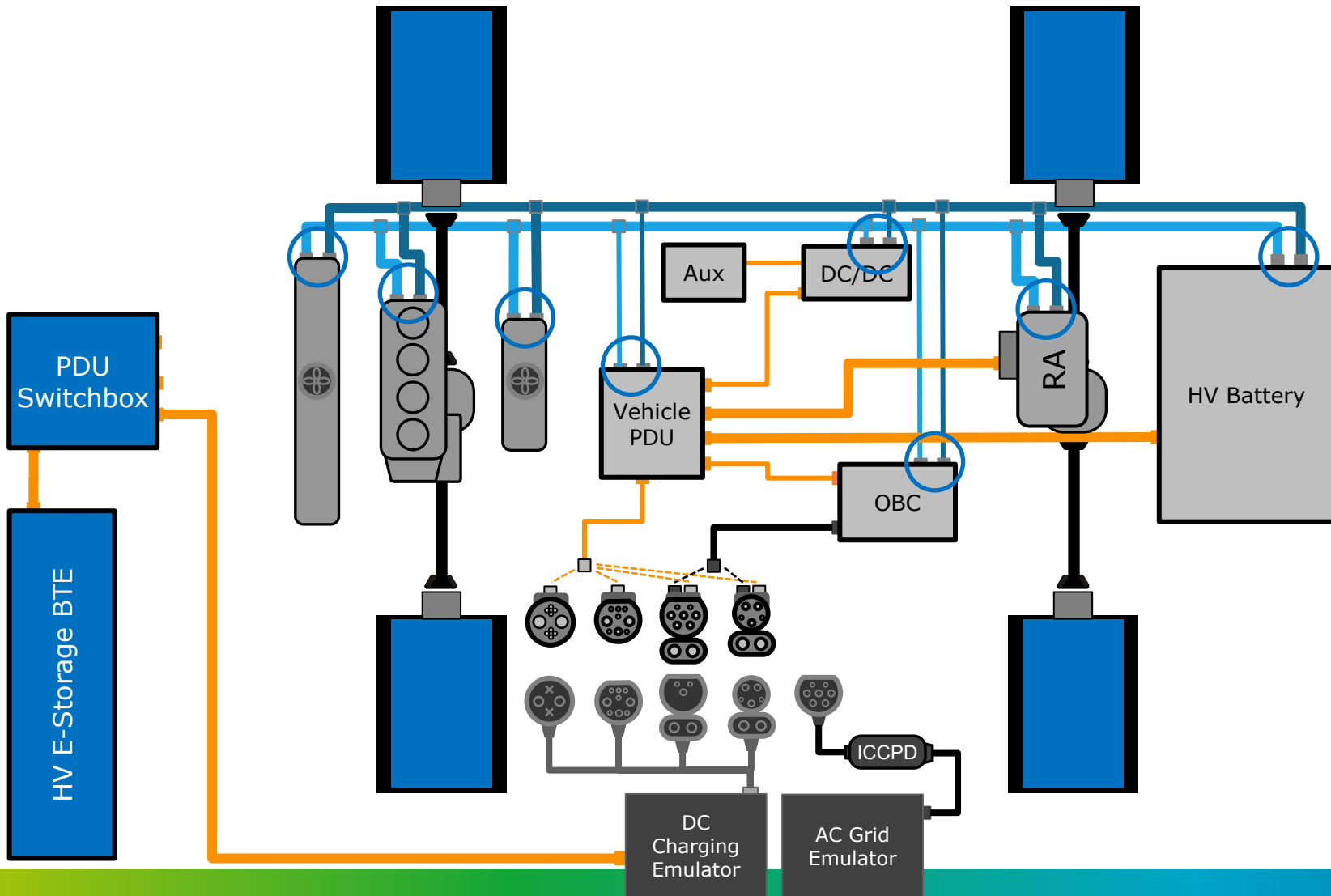

○ Coolant Flow and Temperature

Not shown:
Oil Flow and Temperature

All other temperature measurement
points

Exemplary Instrumentation Setup: Battery Electric Vehicle

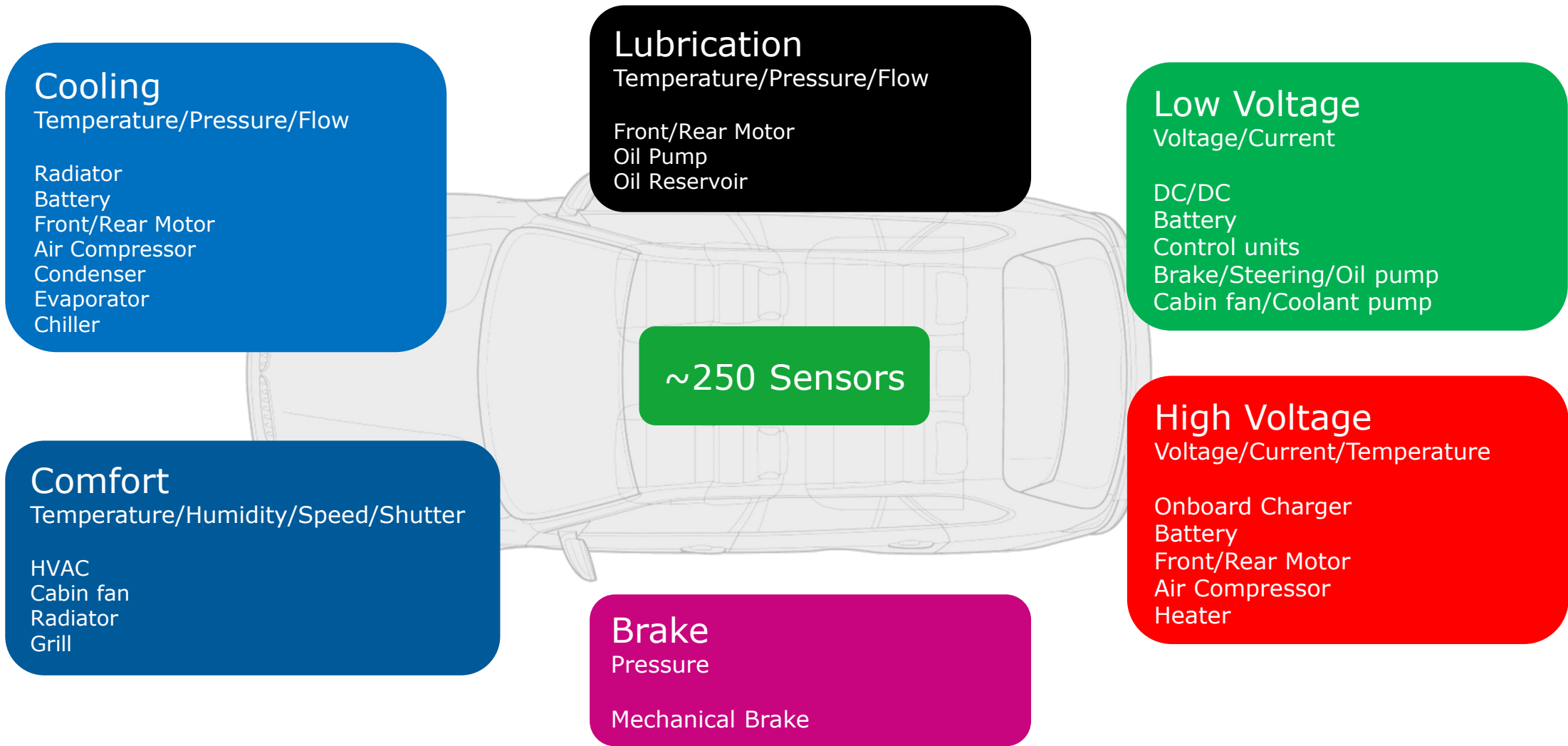



Data Acquisition System

OEM Reference Energy Flow Setup: Measurement Equipment

* >15 AC High Voltage and Currents >30 channels
 >30 DC High Voltage and Currents >60 channels

** ICE E-Motor(s) Inverter(s)

Climatic Testbed

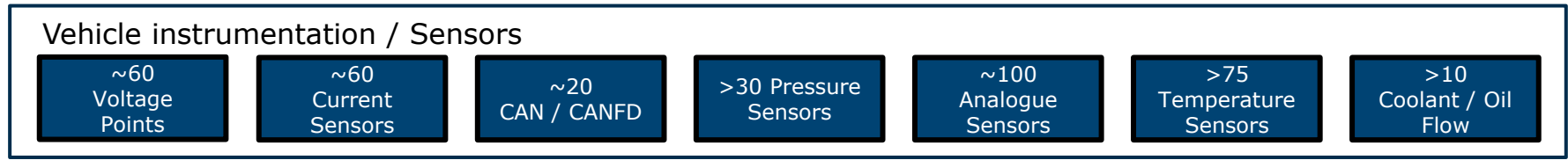
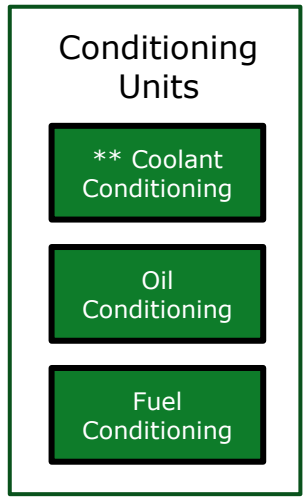
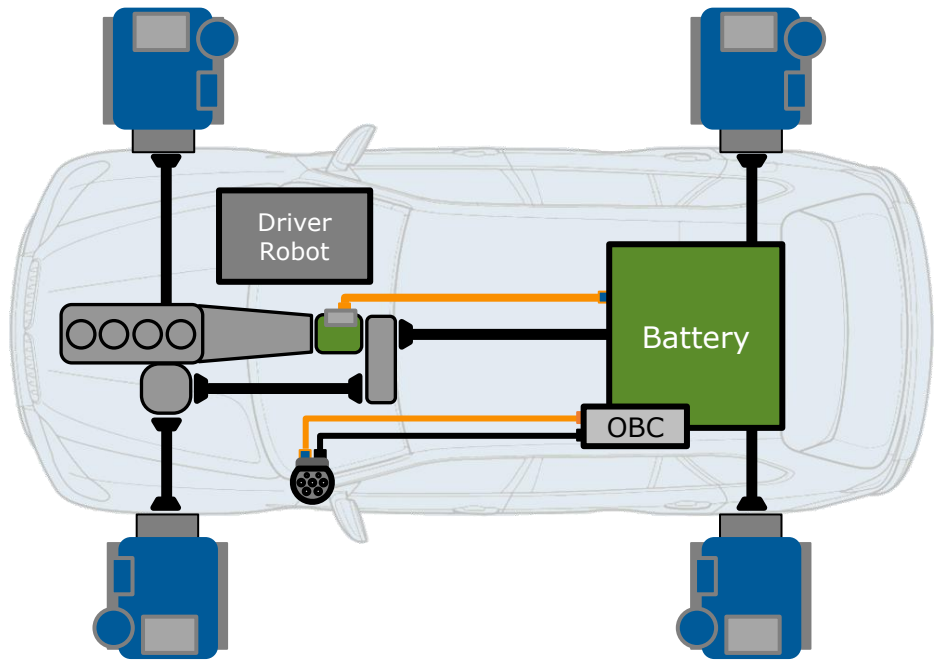
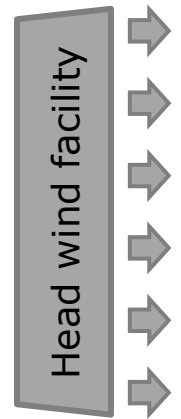
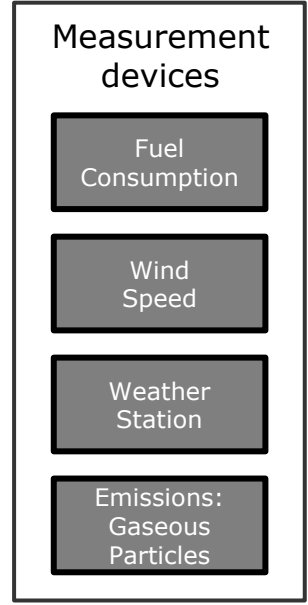
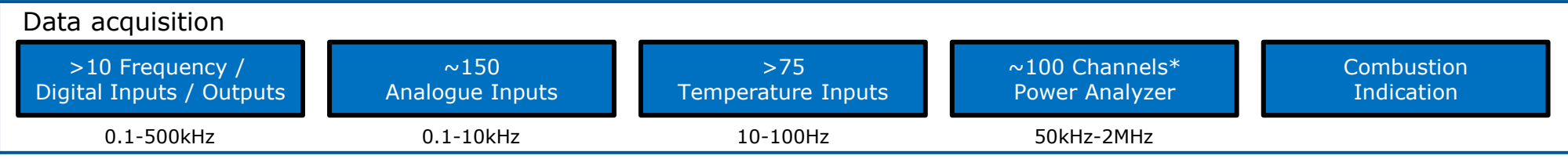

OEM Requirement on Data Acquisition System

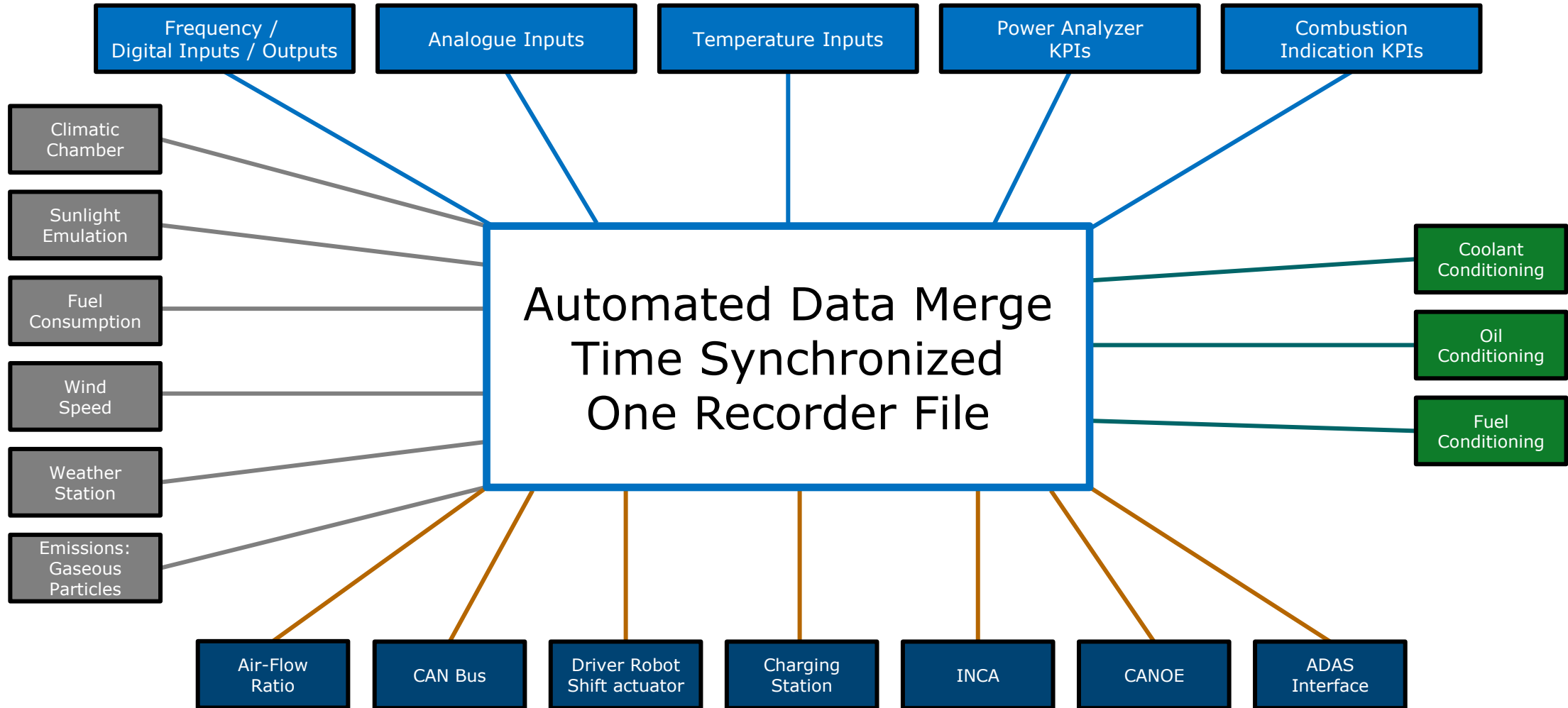

AVL Measurement Solution -Overview

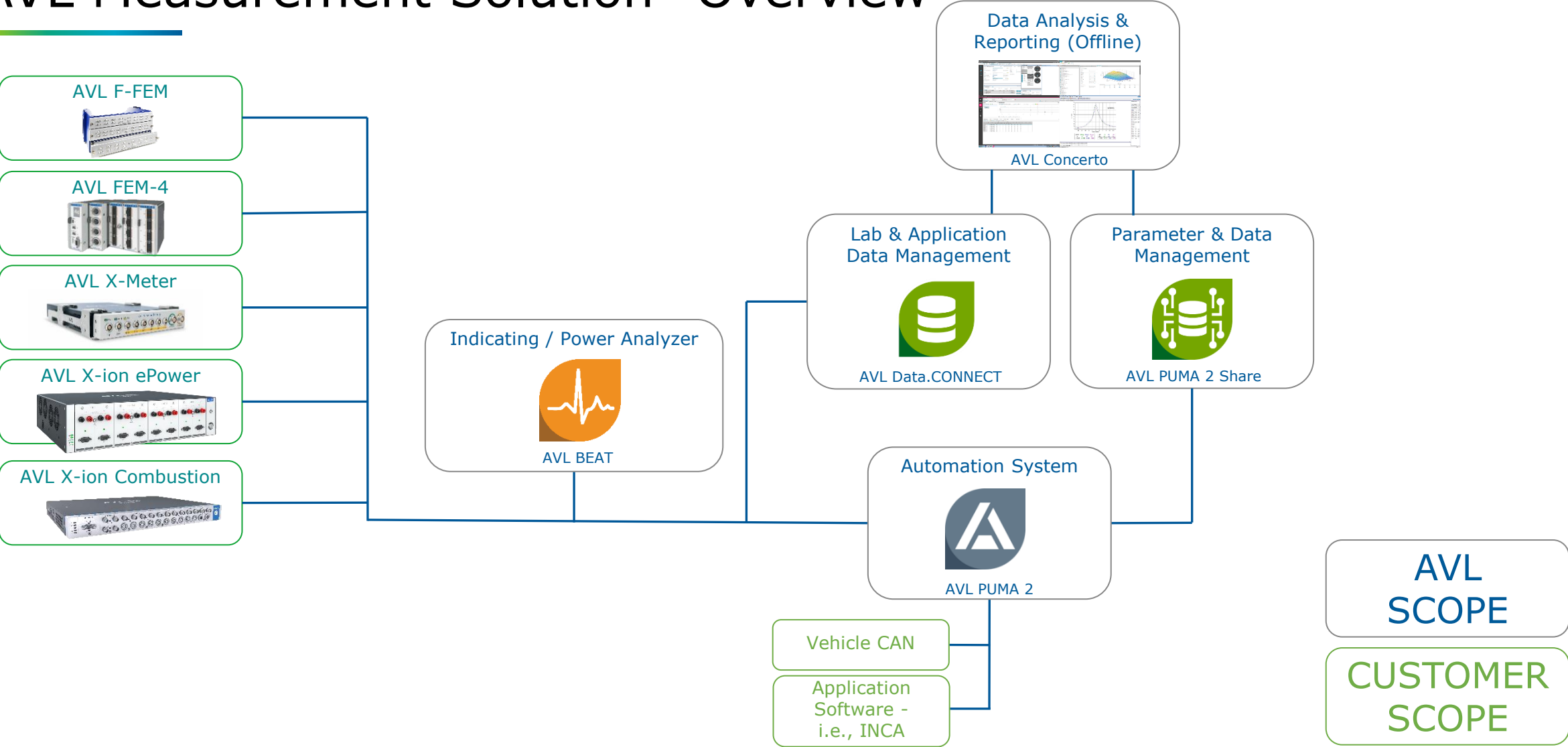

AVL Measurement Solution -Overview

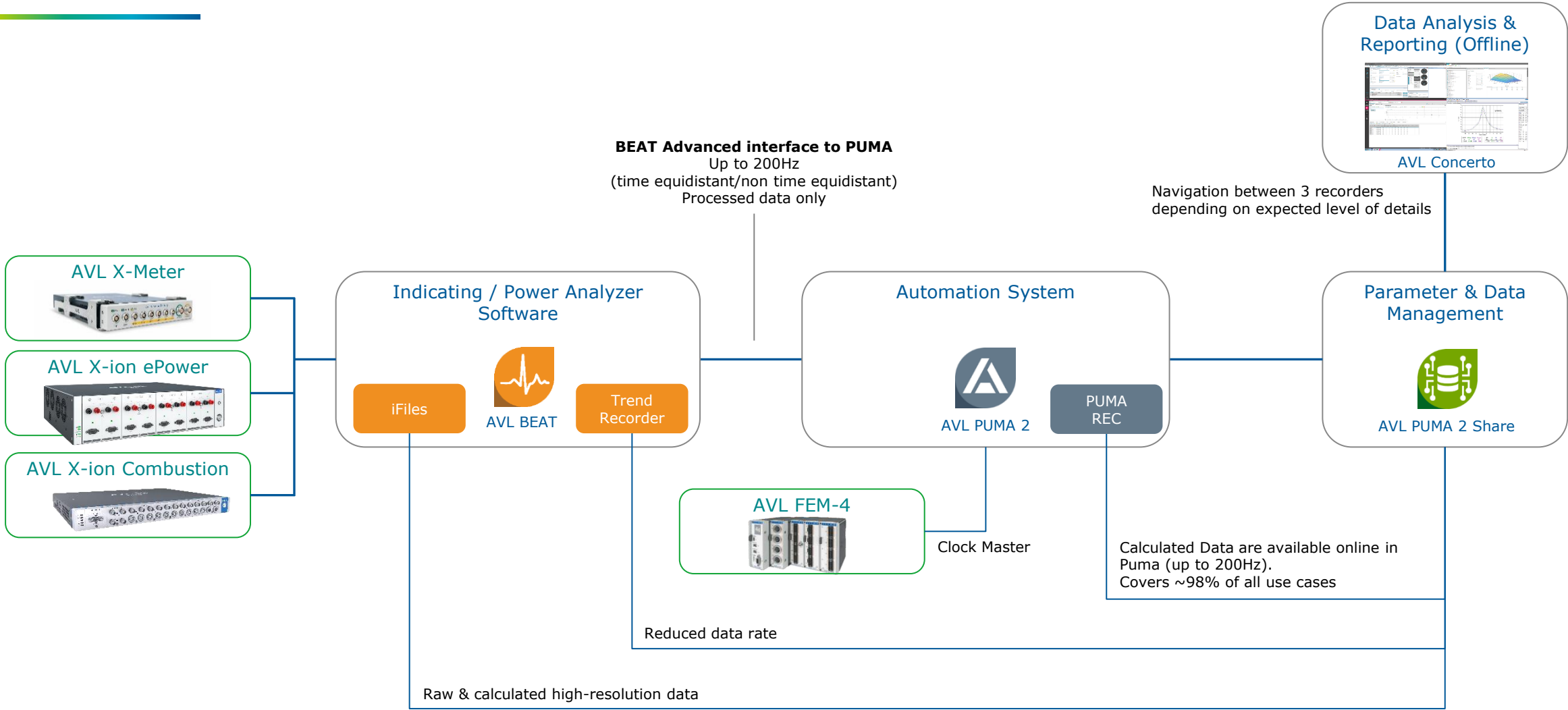

Thank you



www.avl.com